

YAMAHA YZF-R1 15- RACING MID PIPE for R-11Sq

Be sure to read the instruction carefully before starting the work. It is necessary to follow the contents to install Yoshimura product.

Product information



- CAUTION** Before beginning installation, let motorcycle cool down.
- CAUTION** Be sure not to damage each part during installation.
- CAUTION** Torque specification must be followed. If neglected, it may cause bolt and nut to fall off and damage to Yoshimura product and motorcycle.

1. Product Information:

Description	YAMAHA YZF-R1 15- RACING MID PIPE for R-11Sq	Cyclone Type	Y38AS1QC2
Part Number	185-38A-5400	Weight [STD : 6.4kg]	1.8kg
Main Material	Stainless steel		

2. Applicable Model :

Applicable Model	YAMAHA YZF-R1(15-) / YZF-R1M(15-) Yoshimura EEC Slip-On R-11Sq only
Application	<YAMAHA YZF-R1/M EEC Slip-On R-11Sq> Part number : 1F0-38A-L1*G0 (1F0-38A-L1*G0 is applicable for 2017 or later models however it physically fits 2015-2016 models.)



3. Contents:

No.	Descriptions	Part No.	Q'ty
1	Racing Mid Pipe	185-38A-5450	1
2	Cap Bolt M8x40	800-208-5040	1
3	Washer M8x26	812-108-2600	2
4	Flange Nut M8	823-010-1250	1
5	Clamp Band 55-59	162-022-5559	2

Parts Diagram

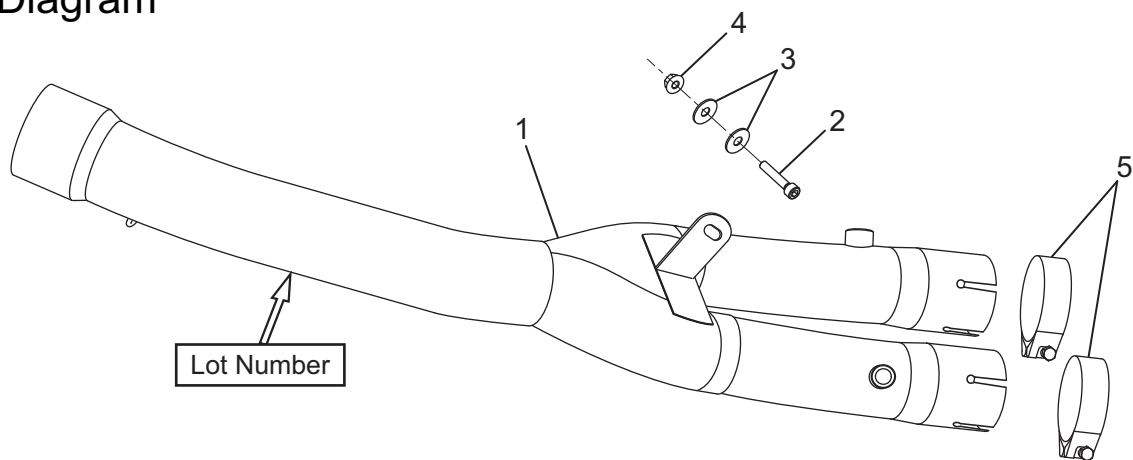

- CAUTION**
In combination with Racing Mid Pipe, the EEC Approval is not valid.

- DANGER**
When this Racing Mid Pipe is installed, the exhaust gas becomes leaner. It requires the readjustment of injection setting by Bazzaz Z-Fi or similar equipment. If neglected, it may cause engine damage.